

MPPT Disconnect RS

865-1036

Quick Start Guide



A Safety Information

Important Information

Read these instructions carefully and look at the equipment to become familiar with the device before trying to install, operate, service or maintain it. The following special messages may appear throughout this documentation or on the equipment to warn of potential hazards or to call attention to information that clarifies or simplifies a procedure.

The addition of either symbol to a "Danger" or "Warning" safety label indicates that an electrical hazard exists which will result in personal injury if the instructions are not followed.

This is the safety alert symbol. It is used to alert you to potential personal injury hazards. Obey all safety messages that follow this symbol to avoid possible injury or death.

DANGER

DANGER indicates a hazardous situation which, if not avoided, will result in death or serious injury.

WARNING

WARNING indicates a hazardous situation which, if not avoided, can result in death or serious injury.

Please Note

Electrical equipment should be installed, operated, serviced, and maintained only by qualified personnel. No responsibility is assumed by Schneider Electric for any consequences arising out of the use of this material. A qualified person is one who has skills and knowledge related to the construction, installation, and operation of electrical equipment and has received safety training to recognize and avoid the hazards involved.

Conventions Used

Section Step Safety Direction Expand Label

Exclusion for Documentation

UNLESS SPECIFICALLY AGREED TO IN WRITING, SELLER

(A) MAKES NO WARRANTY AS TO THE ACCURACY, SUFFICIENCY OR SUITABILITY OF ANY TECHNICAL OR OTHER INFORMATION PROVIDED IN ITS MANUALS OR OTHER DOCUMENTATION;

(B) ASSUMES NO RESPONSIBILITY OR LIABILITY FOR LOSSES, DAMAGES, COSTS OR EXPENSES, WHETHER SPECIAL, DIRECT, INDIRECT, CONSEQUENTIAL OR INCIDENTAL, WHICH MIGHT ARISE OUT OF THE USE OF SUCH INFORMATION. THE USE OF ANY SUCH INFORMATION WILL BE ENTIRELY AT THE USER'S RISK; AND

(C) REMINDS YOU THAT IF THIS MANUAL IS IN ANY LANGUAGE OTHER THAN ENGLISH, ALTHOUGH STEPS HAVE BEEN TAKEN TO MAINTAIN THE ACCURACY OF THE TRANSLATION, THE ACCURACY CANNOT BE GUARANTEED. APPROVED CONTENT IS CONTAINED WITH THE ENGLISH LANGUAGE VERSION WHICH IS POSTED AT [HTTPS://SOLAR.SCHNEIDER-ELECTRIC.COM/](https://solar.schneider-electric.com/).

Contact Information

Schneider Electric Solar Inc.
3700 Gilmore Way, Burnaby B.C., V5G 4M1, Canada
<https://solar.schneider-electric.com/>

Submit your support request online at: <https://solar.schneider-electric.com/tech-support/netsuite/>

990-91312A
12-2019

B Product Safety Information

DANGER

HAZARD OF ELECTRIC SHOCK, EXPLOSION, OR FIRE

This document is in addition to, and incorporates by reference, the relevant product manuals for this device. Before reviewing this document, you must read the relevant product manuals. Unless specified, information on safety, specifications, installation and operation is as shown in the primary documentation for each device. Ensure you are familiar with that information before proceeding.

Failure to follow these instructions will result in death or serious injury.

WARNING

HAZARD OF ELECTRIC SHOCK, EXPLOSION, OR FIRE

- This photovoltaic rapid shutdown equipment (PVRSE) does not perform all of the functions of a complete photovoltaic rapid shutdown system (PVRSS). This PVRSE must be installed with other equipment to form a complete PVRSS that meets the requirements of NEC (NFPA 70) section 690.12 for controlled conductors outside the array.
- Other equipment installed in or on this PV system may adversely affect the operation of the PVRSS.
- It is the responsibility of the installer to ensure that the completed PV system meets the rapid shutdown functional requirements.
- This equipment must be installed according to the manufacturer's installation instructions.

Failure to follow these instructions can result in death, serious injury, or equipment damage.

WARNING

HAZARD OF ELECTRIC SHOCK, EXPLOSION, OR FIRE

- This equipment is not ignition protected. Do not install this product in locations that require ignition-protected equipment. This includes any confined space containing lead acid batteries, or flammable chemicals such as, natural gas (NG), liquid petroleum gas (LPG) or gasoline (Benzine/Petrol).
- Do not install in a confined space with machinery powered by flammable chemicals, or storage tanks, fittings, or other connections between components of fuel or flammable chemical systems. Keep flammable materials a minimum distance of 10 meters (33 feet) from the top surface and 30 cm (12 in) from either side surface and the front of the MPPT Disconnect RS.
- The MPPT Disconnect RS must be mounted vertically and installed indoors in a dry, protected location away from flammable materials, sources of high temperature, moisture, vibration, direct sunlight, dust, and wind-blown debris.

Failure to follow these instructions can result in death, serious injury, or equipment damage.

WARNING

LIMITATIONS OF USE

Do not use this equipment with life support equipment or other medical equipment or devices.

Failure to follow these instructions can result in death, serious injury, or equipment damage.

WARNING

HAZARD OF INJURY OR EQUIPMENT DAMAGE

The installer must provide signage that complies with section 690.56(C) of the NEC (NFPA 70).

Failure to follow these instructions can result in death, serious injury, or equipment damage.

NOTICE

LIGHTNING PROTECTION

To help protect this equipment's insulation and conductors from damage due to a sudden over-voltage surge such as lightning strikes, install a DC-rated lightning arrestor on the DC input line.

Failure to follow these instructions can result in equipment damage.

C Introduction

The MPPT Disconnect RS is an accessory for the Conext MPPT 60 150 and MPPT 80 600 charge controllers. It provides a disconnect for the photovoltaic (PV) circuits, an integrated Rapid Shutdown transmitter, and arc fault detection. Rapid shutdown functionality is achieved only when the PV modules are equipped with compatible models of TIGO® TS4-F (not supplied) installed according to local codes and standards (see the *MPPT Disconnect RS Installation and Owner's Guide (990-91313)* for more information).

D Materials List

NOTE: Before unpacking the MPPT Disconnect RS, check the outer packaging materials for damage. If any damage is found, contact your supplier before proceeding.

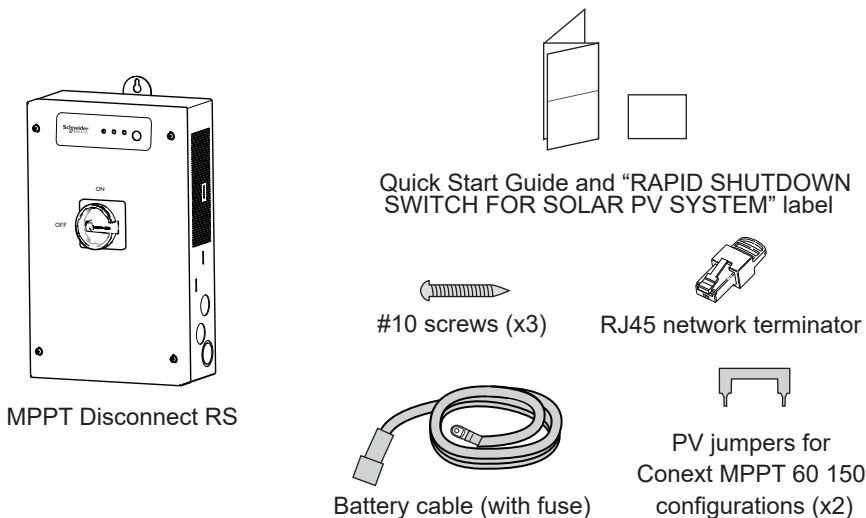

E Physical Features

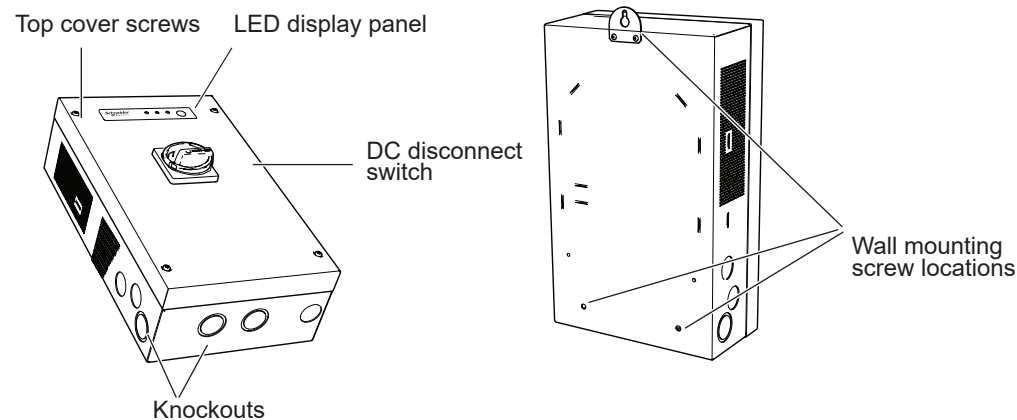

F Tools and Equipment

The following materials and tools are not supplied but are required to complete the installation:

- Personal protective equipment (PPE)
- Voltage meter
- Locks and tags
- Power drill (use only for mounting)
- Screwdriver sets (flat-head and Phillips)
- Wire stripper
- Calibrated torque wrench set for torque values ranging from 0.5–3.1 Nm (0.4–2.3 lb-ft)
- M4 screws for mounting the RSD Initiator switch
- Sprit level

G Lock-out and Tag-out

⚠ DANGER

HAZARD OF ELECTRIC SHOCK, EXPLOSION, OR ARC FLASH

- Apply appropriate personal protective equipment (PPE) and follow safe electrical work practices. See NFPA 70E or CSA Z462.
- This equipment must only be installed by qualified electrical personnel.
- Never energize this equipment with covers removed.
- This equipment is energized from multiple sources. Before removing covers identify all sources, de-energize, lock-out, and tag-out and wait 2 minutes for circuits to discharge.
- Always use a properly rated voltage sensing device to confirm all circuits are de-energized.
- Do not install/store this equipment near flammable material.
- Always verify correct polarity of the PV and Battery terminal connections.
- Ensure that Control and PV cables are properly inserted in their respective terminal blocks.
- Follow all Schneider Electric and battery manufacturer guidelines for battery protection.
- Do not attempt to replace components inside the MPPT Disconnect RS.

Failure to follow these instructions will result in death or serious injury.

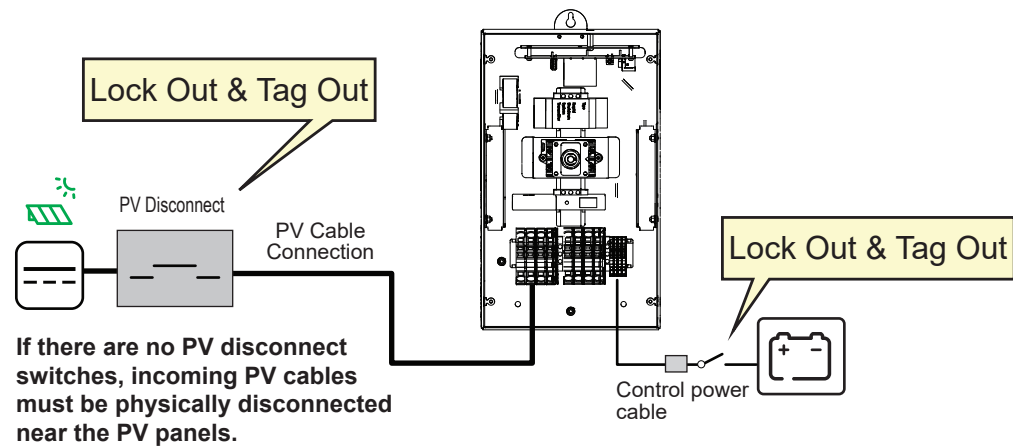

H Wiring – Preparation

NOTICE

EQUIPMENT DAMAGE

Do not drill, cut, or punch holes in the MPPT Disconnect RS. Use only the knockouts provided. You can use either the bottom or side knockouts.

Failure to follow these instructions can result in equipment damage.

- 1 Remove the DC Disconnect switch knob.
- 2 Remove the four front cover screws and then lift off the cover (see section D).
- 3 Remove the knockout plugs for battery, PV array, and network cables and set aside.
- 4 Follow the pre-installation and wiring instructions in the installation manuals for the MPPTs and RS Initiator switch.

IMPORTANT: The RS Initiator switch must be installed in an accessible location, per 690.12 (C) of NEC 2017.

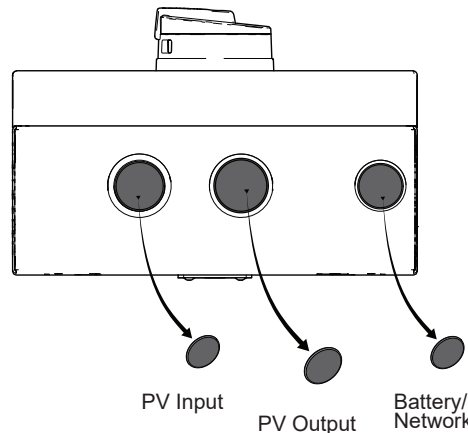

H1 Wiring – Terminal Connections

NOTE: For more information and additional wiring diagrams, see the *MPPT Disconnect RS Installation and Owner's Guide (990-91313)*, and installation guides for all other equipment.

For Conext MPPT 60 150 only:
32 A max. per input channel. Install the provided jumpers between output terminals PV1+ and PV2+, and PV1- and PV2- to combine output channels.

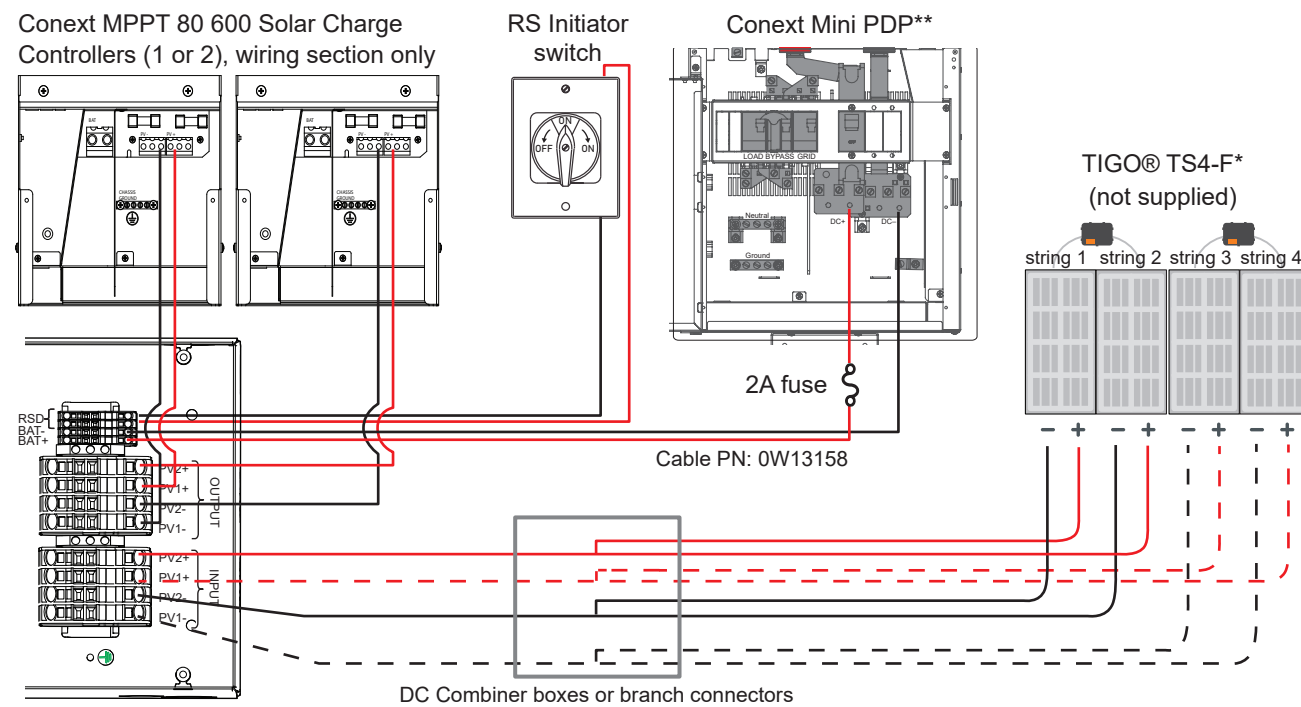
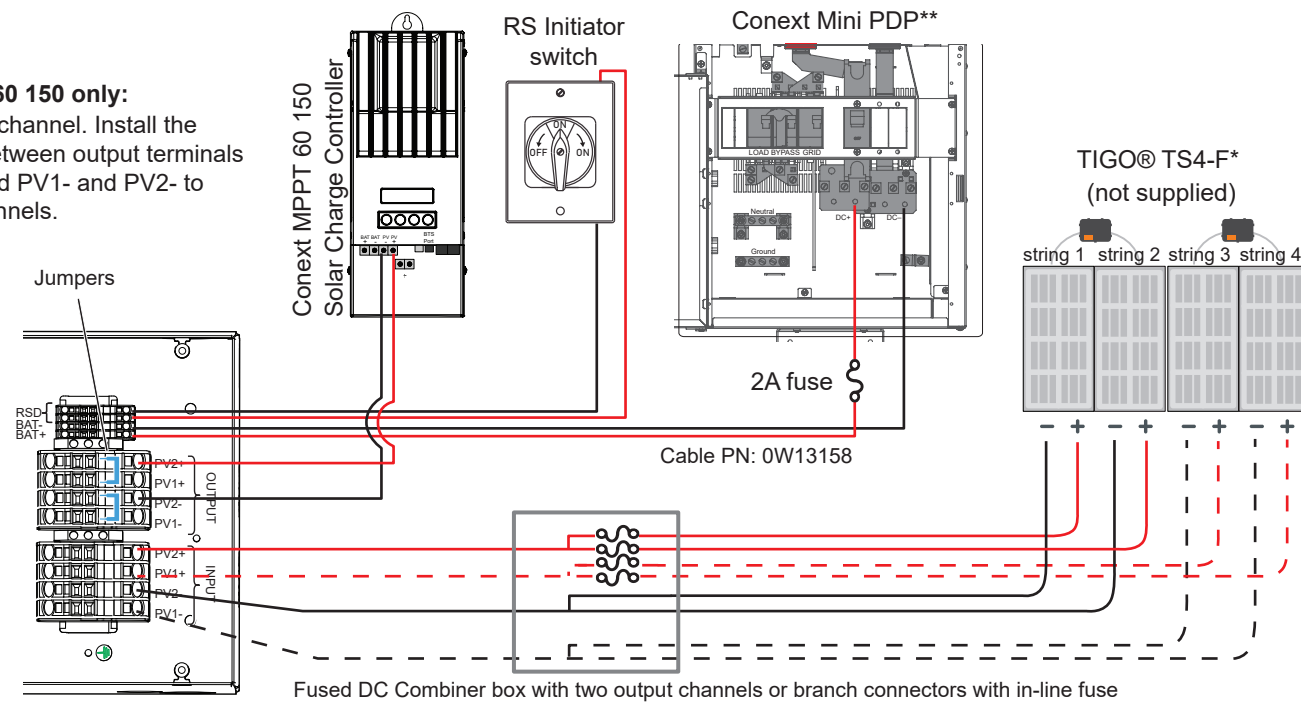

***IMPORTANT:** The Rapid Shutdown functionality is achieved only when the PV modules are equipped with compatible models of TIGO® TS4-F, installed according to local codes and standards. Other TS4 variants are not supported.

**Connect the Bat+ and Bat- cables to the DC terminals in the Conext Power Distribution Panel (PDP), or the Conext Mini PDP. For details, see the Conext Power Distribution Panel Installation Guide (document number 975-0709-01-01) or the Conext Mini Power Distribution Panel Installation Guide (document number 975-0735-01-01).

MPPT Disconnect RS

865-1036

H2 Wiring – Communication Board Connections

⚠️ ⚠️ WARNING

HAZARD OF ELECTRIC SHOCK AND FIRE

Always install the Xanbus cable between the MPPT Disconnect RS and Conext MPPT charge controller. Without Xanbus connections, the disconnection of the system in the event of an arc fault will not be possible.

Failure to follow these instructions can result in death, serious injury, or equipment damage.

NOTE: Depending on your network layout, the terminator may need to be inserted into another device elsewhere in the network.

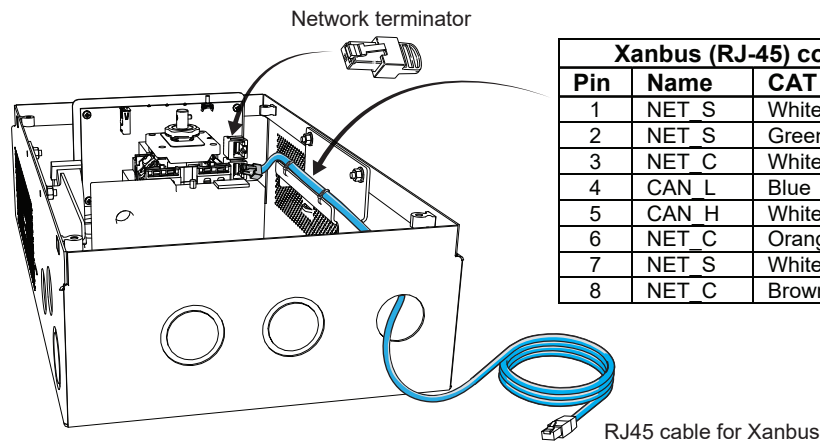

Xanbus (RJ-45) connections		
Pin	Name	CAT 5 cable color
1	NET S	White/Green
2	NET S	Green
3	NET C	White/Orange
4	CAN L	Blue
5	CAN H	White/Blue
6	NET C	Orange
7	NET S	White/Brown
8	NET C	Brown

I Dimensions

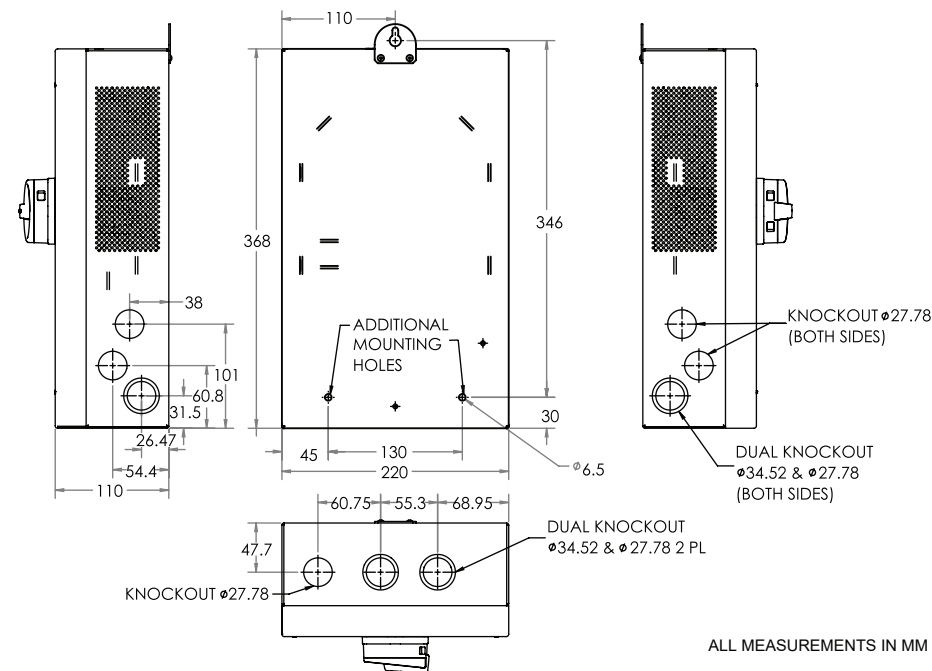

J Commissioning

Pre-Commissioning Inspections



- Clearances are correct.
- Wiring is complete and secure, per the instructions in the Installation and Owner's Guide:
 - DC/PV wiring
 - Earthing
 - Communication Interface with the Conext MPPT charge controllers
 - RSD Initiator switch
- No tools or foreign materials inside the enclosure.
- Front cover is installed, and cover screws are torqued to 2.6 Nm (1.9 ft-lb).
- Each of the PV panels are equipped with compatible models of TIGO TS4-A-F.
- The RS Initiator Switch label 885-91753 is fixed within 1 meter (3 ft) of the RS Initiator Switch assembly (refer to figure 690.56(C)(1)(a) in NEC 2017).

Start-Up Procedure

1. Verify that the DC disconnect switch on the MPPT Disconnect RS is turned OFF.
2. Verify that the battery fuse is in working condition and is installed properly.
3. Check the polarity of the DC and PV wires.
4. Ensure that the maximum DC voltage is not more than 60 V for the battery.
5. Turn ON the battery breaker (external) and wait for the MPPT Disconnect RS to operate, (the **Status** LED should be flashing green).
6. Turn ON the DC switch (external) or reconnect the PV cables at the PV panels.
7. Turn ON the DC Disconnect switch.
8. Turn ON the DC Disconnect switch.
9. Verify that the AFD LED is not red or flashing. Troubleshoot if necessary.
10. Check the status of the indicator lights on the display panel: The **Status** LED should be flashing green. If the **Status** LED is not green, check that:
 - a. All connections are correct.
 - b. The RS Initiator switch is OFF.

If there is sufficient sunlight, the connected charge controller will start producing power.

For more information about the LEDs and troubleshooting, see the *MPPT Disconnect RS Installation and Owner's Guide (990-91313)*.

K Specifications

Electrical specifications	
Max. PV array open circuit voltage	600 VDC
Max. PV current (Isc)	32 A (25.6 A @ STC) x 2 channels
Control power nominal voltage	48 VDC
Control power input range (battery)	22 VDC to 60 VDC
Max. Control Power input current	2 A
Max. and min. wire size in conduit at input	#6 AWG to #14 AWG (8 to 2.5 mm ²)

K Specifications

Electrical specifications	
Max. PV array open circuit voltage	600 VDC
Conductor type	Certified for use with 75°C copper conductors
PV Input and Output connection	Push In cage clamp, CU type cable compatible
Battery connection	Push In cage clamp, CU type cable compatible
RS Initiator switch connection	Push In cage clamp, CU type cable compatible
General specifications	
Ambient air temperature for operation	-20°C to 50°C (-4°F to 122°F)
Storage temperature range	-40°C to 85°C (-40°F to 185°F)
Relative humidity	Less than 85%, non-condensing
Operating altitude	Sea level to 6562 ft (2000 m)
Regulatory	
Safety	CSA certified to UL1741, UL1741 CRD - PV Rapid Shutdown, UL1699B, CSA C22.2 No. 107.1-16, CSA C22.2 No.292-18, CSA (LTR) No. AE-004-2015
EMC	FCC and Industry Canada (Class B)
Rapid Shutdown Initiator Switch (ordered separately)	
Part number	865-1039
Enclosure type	NEMA 4x
Ambient air temperature for operation	-20°C to 50°C (-4°F to 122°F)
Compatible products	
Conext MPPT charge controller	Conext MPPT 80 600, Conext MPPT 60 150
Rapid Shutdown Receivers	<ul style="list-style-type: none"> ■ TS4-F ■ TS4-R-F <ul style="list-style-type: none"> ■ TS4-A-F ■ TS4-A-2F
Fastener type	
Front cover screws	2.6 (1.9)
DC switch knob fastener	0.5-0.7 (0.4-0.5)
Plastic nut for DC switch	2-2.5 (1.5-1.8)
Wall mounting screws	3.1 (2.3)
Ground/Earth nut	2.7 (1.99)